

# DIAMOND DIESEL and TURBOCHARGER SERVICE, Inc.

Section 7

Fuel System

Section 7

4 - 1

Fuel Injection Pump

4 - 1

## Fuel Injection Pump - Removal and Replacement

### Component Identification

- 1 Fuel injection pump
- 2 Pump fixing nuts (3 off)
- 3 Injection pump gear cover
- 4 Injection pump lock bolt
- 5 Keyhole washer
- 6 Cold start advance solenoid
- 7 Electric shut-off solenoid (ESOS)
- 8 Fuel line connector (inlet)
- 9 Fuel bleed-off connector
- 10 Turbo boost vacuum pipe (if fitted)
- 11 Drive shaft nut
- 12 Drive gear
- 13 Blanking plug (access for crankshaft locking pin)
- 14 Injection pump oil seal
- 15 Throttle lever

### Service Tools

Item	Part Number	Description
A	892/01148	Timing pin - crankshaft
B	892/01154	Socket - Injection pump gear cover
C	892/01147	Crankshaft turning tool
D	892/01169	Top dead centre setting tool (see page 7/4-2)
E	892/01155	Gear removal tool comprises:
F		Reaction cap
G		Tool body
H		Special bolt
J	General	'C' shaped ring spanner - Injection pump inner nut

### Torque Settings

Item	Nm	lbf ft
4	12	8.8

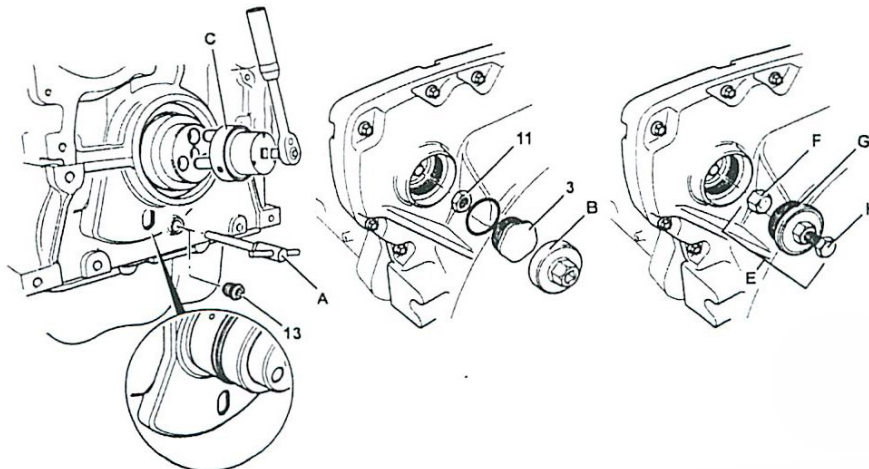
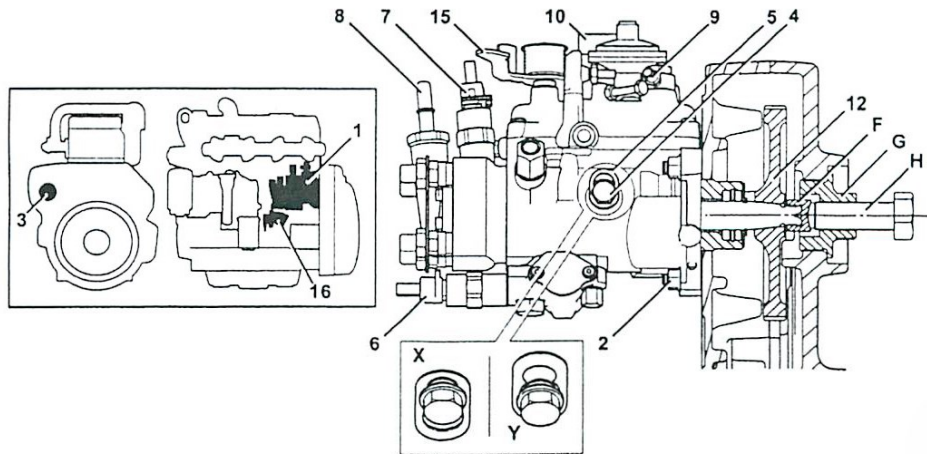

# DIAMOND DIESEL and TURBOCHARGER SERVICE, Inc.

Section 7

Fuel System

Section 7

4 - 2

Fuel Injection Pump

4 - 2

## Fuel Injection Pump - Removal and Replacement

### Before removing:

- 1 Ensure that the engine cannot be started.
- 2 Release the fuel line couplings at the inlet connection 8 and bleed-off connection 9 on the pump. Remove the high pressure fuel lines, see **Fuel Lines - Removal and Replacement**.
- 3 Release the fuel line couplings at the fuel lift pump connections 18 and disconnect the throttle cable.

**IMPORTANT NOTE:** DO NOT attempt to remove the fuel injection pump until both the engine and pump are mechanically locked in the correct position - refer to the procedures below. The pump will need the timing reset by a fuel injection equipment specialist if it is not locked in the correct position prior to removal.

### Removal

- 1 Uncouple the electrical connectors at the shut-off solenoid (ESOS) 7 and cold advance solenoid 6.
- 2 **Turbocharged Engines Only:** Disconnect the boost control vacuum pipe 10 at the diaphragm on the injection pump.
- 3 Remove the taper blanking plug 13.
- 4 Set number 1 piston to top dead centre (on its compression stroke):
  - 4.1 Remove the fuel lift pump see **Fuel Lift Pump - Removal and Replacement**.
  - 4.2 Install the TDC setting tool D, use one of the lift pump retaining bolts 17 to hold the tool in position. Make sure that the top hole locates centrally over the lift pump actuating pin 19.
  - 4.3 Use rotation tool B and turn the crankshaft until timing pin A engages in the crankshaft timing hole. Check that the lift pump actuating pin is protruding from the face of the setting tool as shown, if not complete steps 4.4 and 4.5.
  - 4.4 Remove the timing pin A.
  - 4.5 Rotate the crank pulley 360° and refit the timing pin A

**Note:** The timing pin MUST be engaged in the crankshaft timing hole. It is possible that the pin may appear to 'engage' but it is in fact between the crankshaft webbing. Always check the pin has engaged correctly by trying to move the crankshaft clockwise and anti-clockwise. If you can not turn the crankshaft in both directions, the pins will be engaged.

- 5 Remove fuel injection pump gear cover 3 using service tool B and a suitable ratchet drive.
- 6 Undo and remove the drive shaft nut 11.
- 7 Loosen lock bolt 4 on the fuel injection pump so that the special keyhole washer 5 can be slid across to its locking position (as shown at Y). Screw the lock bolt in and torque tighten, see **Torque Settings**. The washer 5 should be loose.

- 8 Undo and remove the nuts 2. Use special spanner J to undo the nut close to the cylinder block. Be sure to remove all 3 nuts.

- 9 Fit reaction cap F (service tool) over the pump shaft. Screw service tool G to the housing. Using a suitable ratchet drive and socket screw in bolt H (service tool) until resistance is felt.

- 10 The injection pump drive gear 12 is located on a taper on the pump drive shaft. To remove the pump the taper lock must be 'broken'. Support the fuel injection pump. Tap the end of bolt H with a soft faced hammer. When the taper 'breaks' there will be an audible sound.

**Note:** The pump drive gear connects to the injection pump drive shaft by means of taper lock alone. There is no mechanical locking key.

- 11 Withdraw the pump from the flywheel housing. Remove service tools H, G and F.

**IMPORTANT NOTE:** DO NOT remove the engine locking pin A. Make sure that no one attempts to turn the engine.

**IMPORTANT NOTE:** DO NOT loosen the fuel injection pump lock bolt 4.

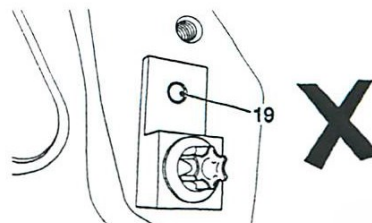
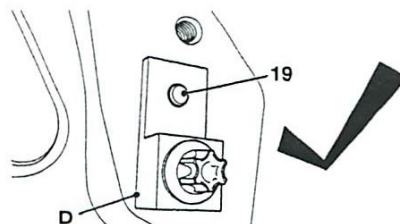
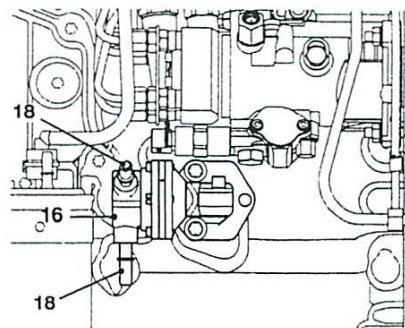



# DIAMOND DIESEL and TURBOCHARGER SERVICE, Inc.

Section 7

Fuel System

Section 7

4 - 3

Fuel Injection Pump

4 - 3

## Fuel Injection Pump - Removal and Replacement (cont'd)

### Component Identification

- 1 Fuel injection pump
- 2 Pump fixing nuts (3 off)
- 3 Injection pump gear cover
- 4 Injection pump lock bolt
- 5 Keyhole washer
- 6 Cold start advance solenoid
- 7 Electric shut-off solenoid (ESOS)
- 8 Fuel line connector (inlet)
- 9 Fuel bleed-off connector
- 10 Turbo boost vacuum pipe (if fitted)
- 11 Drive shaft nut
- 12 Drive gear
- 13 Blanking plug (access for crankshaft locking pin)
- 14 Injection pump oil seal
- 15 Throttle lever
- 16 Seal

### Service Tools

Item	Part Number	Description
A	892/01148	Timing pin - crankshaft
B	892/01154	Socket - Injection pump gear cover
J	General	'C' shaped ring spanner - Injection pump inner nut

### Torque Settings

Item	Nm	lbf ft
3	70	51.6
4	12	8.8
11	25	18.4 1st Stage
11	90	66.3 Final Stage

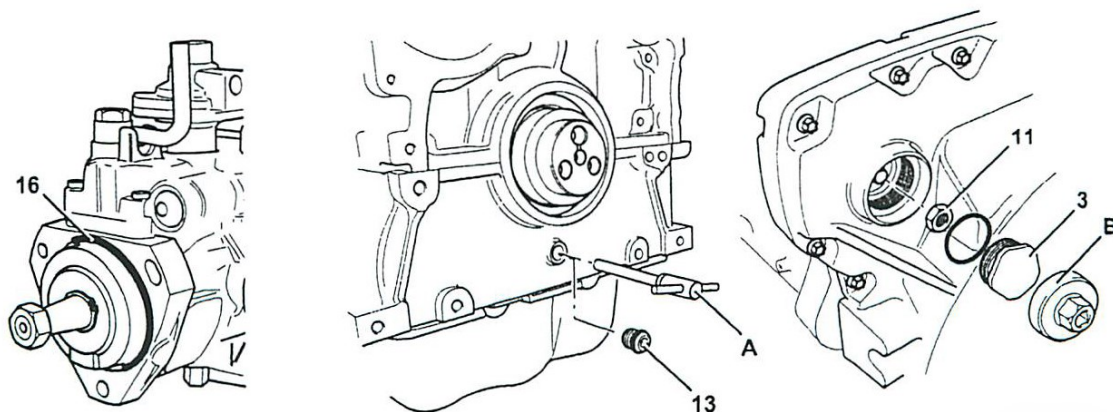
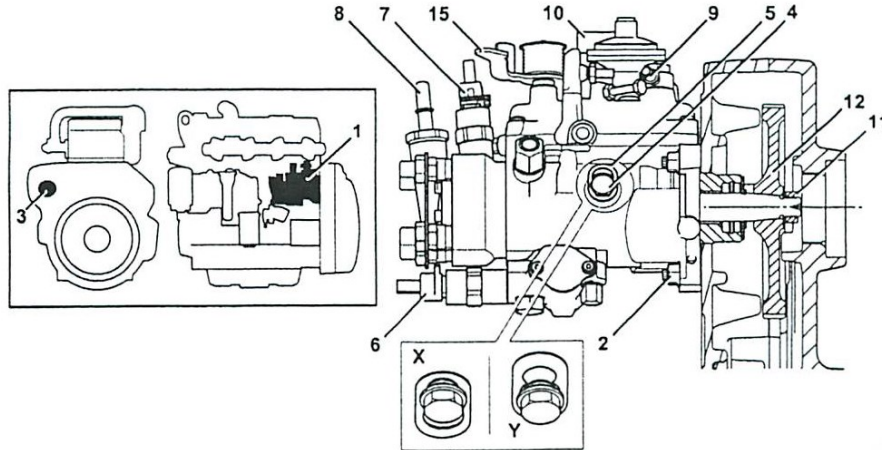

# **DIAMOND DIESEL and TURBOCHARGER SERVICE, Inc.**

Section 7

Fuel System

Section 7

4 - 4

Fuel Injection Pump

4 - 4

## Fuel Injection Pump - Removal and Replacement (cont'd)

### Replacement

Service procedures on the fuel injection pump can only be carried out by specialist personnel with the relevant training and equipment. Before replacing an injection pump with a new one, or one that has been serviced, make sure that the drive shaft is locked, with bolt 4 tightened with keyhole washer 5 in the correct position. Make sure that the engine is still locked in the correct position.

- 1 Make sure that taper surfaces on the injection pump drive shaft and gear 12 are clean and free from oil.
- 2 Make sure that the oil seal 16 is correctly located on the injection pump mounting face. Locate the pump onto the mounting studs. Locate the drive gear 12 over the pump drive shaft.
- 3 Fit and torque tighten the nuts 2 to 24 Nm (17.7 lbf ft). Use special spanner H to tighten the nut close to the cylinder block.
- 4 Fit and torque tighten the pump gear nut 11 to the 1st stage pre torque. See **Torque Settings**.

**Note:** If the washer is supplied with a replacement pump, DO NOT FIT THE WASHER. Secure the gear with the nut 11 only.

- 5 Loosen lock bolt 4 until the keyhole washer 5 can be slid under the bolt (as shown at X). Then torque tighten bolt 4, See **Torque Settings**. The washer 5 should be locked.
- 6 Torque tighten pump gear nut 11 to final stage, See **Torque Settings**.
- 7 Fit the gear cover 3 using service tool. Make sure its sealing 'O' ring is correctly fitted. Torque tighten the gear cover, See **Torque Settings**.
- 8 Remove the engine lock pin A and refit the blanking plug B.
- 9 Couple the electrical connectors at the shut-off solenoid (ESOS) 7 and cold advance solenoid 6.
- 10 **Turbocharged Engines Only:** Reconnect the boost control vacuum pipe 10 at the diaphragm on the injection pump.

### After replacing:

- 1 Replace the rocker cover, see Section 12 **Base Engine, Cylinder Head**.
- 2 Reconnect the fuel line couplings at the inlet connection 8 and bleed-off connection 9 on the pump. Fit the high pressure fuel lines, see **Fuel Lines - Removal and Replacement**.
- 3 Remove the TDC setting tool and replace the fuel lift pump, see **Fuel Lift Pump - Removal and Replacement**.
- 4 Reconnect the throttle cable.
- 5 Bleed the fuel system, see Section 3 **Routine Maintenance**.
- 6 Start the engine and check for fuel leaks.

Call:

**1-800-4-DIESEL**